

MS-I8S PROCESSOR

Installation and Specifications:

This device complies with part 15 of the FCC Rules. Operation is subject to the following two conditions: (1) This device may not cause harmful interference, and (2) this device must accept any interference received, including interference that may cause undesired operation.

1. General:

The MS-I8S is part of Mercury Security's bridging hardware technology for replacing the Software House I8-CSI module that provides sensor monitoring when migrating to the Mercury platform. Mercury's MS-I8S board has eight inputs, which may be configured to support unsupervised or supervised alarm input circuits. In addition, one dedicated input is provided for cabinet tamper switch monitoring. The MS-I8S requires 12 Vdc for power.

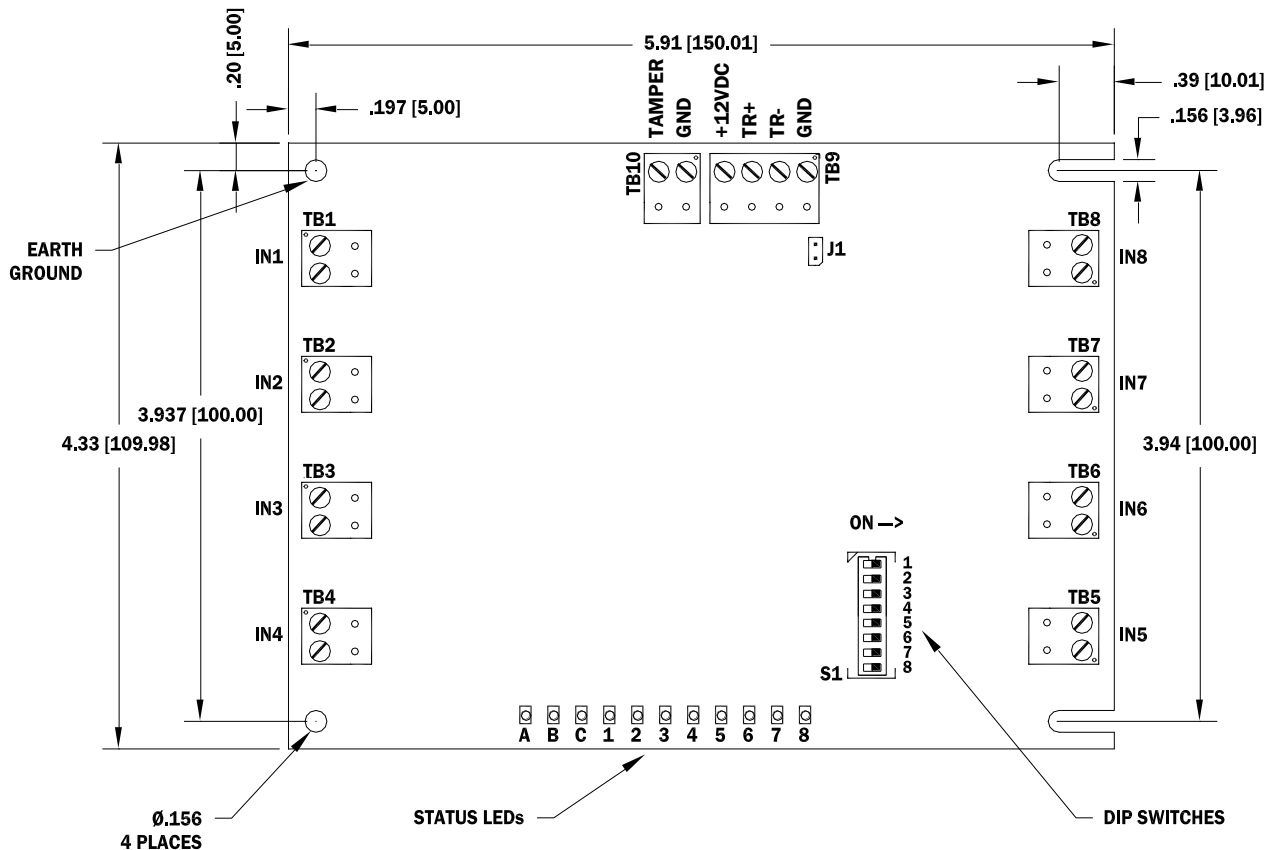

2. Supplying Power to the MS-I8S:

The MS-I8S requires 12 Vdc for power.

TB9 pin 1: Ground

TB9 pin 4: +12 VDC

Locate power source as close to the unit as possible. Connect power with minimum of 18 AWG wires.

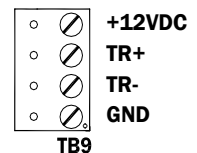

 **Observe POLARITY!**

3. Communication Wiring:

The MS-I8S communicates to the MS-ICS intelligent controller via a 2-wire RS-485 interface. The interface allows multi-drop communication on a single bus of up to 4,000 feet (1,200 m). Shielded cable of 24 AWG with characteristic impedance of 120 ohm is specified for the RS-485 interface.

⚠ The last devices on each end of the cable should have the terminator installed (install jumper J1).

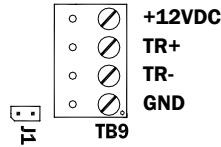

4. Alarm Inputs Wiring:

Input circuits can be configured as unsupervised or supervised. When unsupervised, reporting consists of only the open or closed states.

When an input circuit is configured for supervision, then the MS-I8S board also monitors the following abnormal circuit conditions: open circuit, shorted circuit, the grounding of either side of the circuit*, or the introduction of a foreign voltage*. A supervised input circuit requires adding two resistors to the circuit to facilitate proper reporting. The standard supervised circuit requires 1k Ohm, 1 % resistors and should be located as close to the sensor as possible. Custom end of line (EOL) resistances may be configured via the host software.

* Grounded and foreign voltage states are not UL 294 required and therefore not verified by UL. The input circuit wiring configurations shown are supported, but may not be typical:

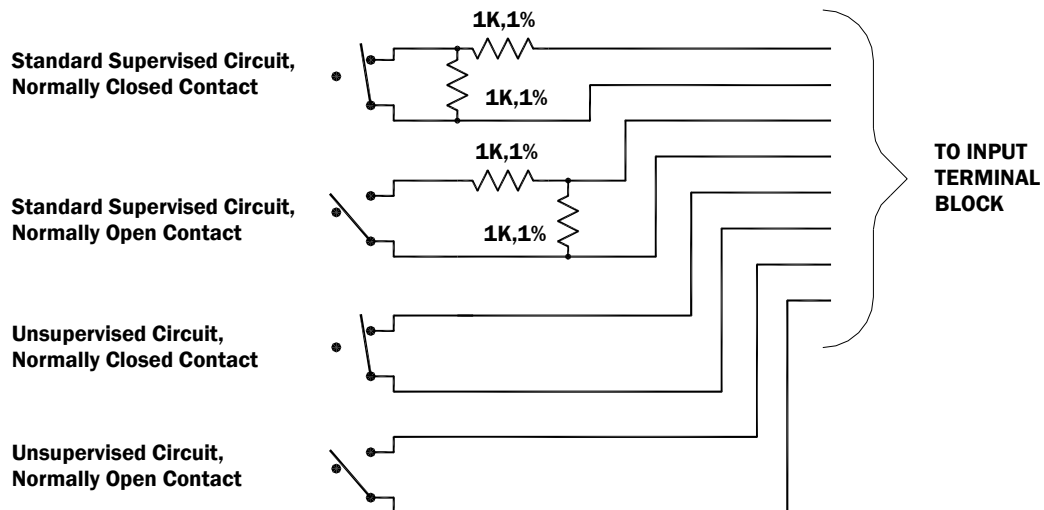

5. Cabinet Tamper Switch Input Wiring:

Connect TB10 terminals to the cabinet tamper switch. The cabinet tamper switch must be a normally closed contact. Do not use EOL resistor(s). Install a jumper wire to these terminals if a cabinet tamper switch is not used.

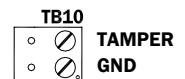

6. DIP Switch Jumper and Usage:

Switches 1 to 5 select the device address. Switch 6 and 7 select the communication baud rate. Switch 8 enables encrypted communication. All other configuration settings are set via host software.

S8	S7	S6	S5	S4	S3	S2	S1	SELECTION
			OFF	OFF	OFF	OFF	OFF	Address 0
			OFF	OFF	OFF	OFF	ON	Address 1
			OFF	OFF	OFF	ON	OFF	Address 2
			OFF	OFF	OFF	ON	ON	Address 3
			OFF	OFF	ON	OFF	OFF	Address 4
			OFF	OFF	ON	OFF	ON	Address 5
			OFF	OFF	ON	ON	OFF	Address 6
			OFF	OFF	ON	ON	ON	Address 7
			OFF	ON	OFF	OFF	OFF	Address 8
			OFF	ON	OFF	OFF	ON	Address 9
			OFF	ON	OFF	ON	OFF	Address 10
			OFF	ON	OFF	ON	ON	Address 11
			OFF	ON	ON	OFF	OFF	Address 12
			OFF	ON	ON	OFF	ON	Address 13
			OFF	ON	ON	ON	OFF	Address 14
			OFF	ON	ON	ON	ON	Address 15
			ON	OFF	OFF	OFF	OFF	Address 16
			ON	OFF	OFF	OFF	ON	Address 17
			ON	OFF	OFF	ON	OFF	Address 18
			ON	OFF	OFF	ON	ON	Address 19
			ON	OFF	ON	OFF	OFF	Address 20
			ON	OFF	ON	OFF	ON	Address 21
			ON	OFF	ON	ON	OFF	Address 22
			ON	OFF	ON	ON	ON	Address 23
			ON	ON	OFF	OFF	OFF	Address 24
			ON	ON	OFF	OFF	ON	Address 25
			ON	ON	OFF	ON	OFF	Address 26
			ON	ON	OFF	ON	ON	Address 27
			ON	ON	ON	OFF	OFF	Address 28
			ON	ON	ON	OFF	ON	Address 29
			ON	ON	ON	ON	OFF	Address 30
			ON	ON	ON	ON	ON	Address 31
	OFF	OFF						115,200 BPS
	OFF	ON						9,600 BPS
	ON	OFF						19,200 BPS
	ON	ON						38,400 BPS
OFF								Encrypted communication not required
ON								Encrypted communication required

7. Status LEDs:

Power-up: All LED's OFF

Initialization: Once power is applied, initialization of the module begins

When initialization is completed, LEDs A, B, C, 1 through 8 are briefly sequenced **ON** then **OFF**.

Run time: After the above sequence, the LEDs have the following meanings:

A LED: Heartbeat and On-Line Status:

Off-line: 1 sec rate, 20% **ON**

On-line:

Non-encrypted communication: 1 sec rate, 80% **ON**

Encrypted communication:

.1 sec **ON**, .1 sec **OFF**, .1 sec **ON**, .1 sec **OFF**, .1 sec **ON**, .1 sec **OFF**, .1 sec **ON**, .3 sec **OFF**

A LED Error Indication:

Waiting for application firmware to be downloaded: .1 sec **ON**, .1 sec **OFF**

B LED: SIO Communication Port Status:

Indicates communication activity on the communication port

1 LED: Input Status: 1

2 LED: Input Status: 2

3 LED: Input Status: 3

4 LED: Input Status: 4

5 LED: Input Status: 5

6 LED: Input Status: 6

7 LED: Input Status: 7

8 LED: Input Status: 8

C LED: Cabinet Tamper

Input in the inactive state: **OFF (briefly flashes ON every 3 seconds)**

Input in the active state: **ON (briefly flashes OFF every 3 seconds)**

Input in a fault state: **Rapid Flash**

8. Specifications:

The processor is for use in low voltage, class 2 circuit only.

The installation of this device must comply with all local fire and electrical codes.

Primary power: 12 Vdc \pm 10%, 130 mA maximum

Inputs: 8 unsupervised/supervised, standard EOL: 500/1k/1k ohm, 1%, 1/4 watt

1 unsupervised, dedicated for cabinet tamper

Communication: 2-wire RS-485. 9600, 19200, 38400, or 115200 bps

Cable requirements:

Power: 18 AWG, 1 twisted pair

RS-485: 24 AWG, 120 ohm impedance, twisted pair with shield, 4,000 ft. (1,200 m) maximum

Alarm inputs: 1 twisted pair, 30 ohms maximum

Mechanical:

Dimension: 4.33" (110 mm)W x 5.90" (150 mm)L x .65" (16.5 mm)H
Weight: 2.7 oz. (77.3 g) nominal (w/o terminal blocks)

Environmental:

Temperature: -55 °C to +85 °C, storage
0 °C to +50 °C, operating
Humidity: 5% to 95% RHNC

Warranty

Mercury Security warrants the product is free from defects in material and workmanship under normal use and service with proper maintenance for one year from the date of factory shipment. Mercury Security assumes no responsibility for products damaged by improper handling or installation. This warranty is limited to the repair or replacement of the defective unit.

There are no expressed warranties other than set forth herein. Mercury Security does not make, nor intends, nor does it authorize any agent or representative to make any other warranties, or implied warranties, and expressly excludes and disclaims all implied warranties of merchantability or fitness for a particular purpose.

Returns must be accompanied by a Return Material Authorization (RMA) number obtained from customer service, and prepaid postage and insurance.

Liability

The Interface should only be used to control exits from areas where an alternative method for exit is available. This product is not intended for, nor is rated for operation in life-critical control applications. Mercury Security is not liable under any circumstances for loss or damage caused by or partially caused by the misapplication or malfunction of the product. Mercury Security's liability does not extend beyond the purchase price of the product.