

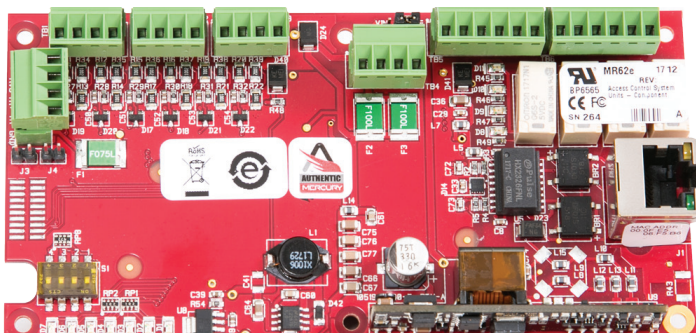

The PremiSys Series 3 PoE One-Door Reader Board enables system expansion of PremiSys intelligent controllers as part of a distributed architecture. The enhanced modules offer an improved processor and increased memory, plus feature an embedded crypto memory chip that provides a secured layer of encryption to onboard sensitive data. Built on the Authentic Mercury open platform, Series 3 modules provide the necessary flexibility to choose the controller configuration that meets the requirements for the installation.

The PREM-BRD1POE-S3 is an IP-enabled interface module with on-board flexibility to connect a wide range of security devices. The PREM-BRD1POE-S3 is easy to install and provides the required I/O for interfacing one card reader using OSDP protocol, six general-purpose input monitor points, and four control relays to any PremiSys series intelligent controller.

The PREM-BRD1POE-S3 provides increased output using PoE+ and provides one reader port supporting OSDP Secure Channel readers, including non-keypad, keypad, and biometric readers. System configuration and setup are provided through the PremiSys software.



Features and Benefits

IP-to-the-Door

- Edge-capable input/output module supporting PoE+ power
- Provides up to 1.5 A of power at door for reader, lock, and more

Security and Network

- IPv4
- Intelligent controller to 62e communications protected by TLS 1.2/1.1 or AES-256/128
- Generate and load custom peer certificates for TLS
- FIPS 140-2 user of OpenSSL
- Port-based network access control using 802.1X
- Zerconf Device Discovery (mDNS)

Card Reader Functions

- OSDP readers only
- Supports multiple card formats, paired and alternate readers, elevator, turnstile, and biometric devices
- Anti-passback support (area, reader, and time-based)
- **Open Architecture:** High performance, reliable platform enables use of hardware with PremiSys access control
- **IP-to-the-Door:** Supports PoE+ power, removing the cost of traditional power supplies and homerun wiring
- **OSDP Protocol:** Supports OSDP and Secure Channel communications
- **Enhanced Security:** Embedded crypto memory chip provides secured layer of encryption to protect sensitive data
- **Versatile Interoperability:** Same reliable interface and identical footprint as the Series 2 PoE One-Door Reader Board, enabling seamless upgrades for existing deployments

Mercury Part # MR62e

PremiSys Series 3 PoE One-Door Reader Board (1 OSDP Reader, 6 Inputs, 4 Outputs) PREM-BRD1POE-S3

PremiSys Series 3 PoE One-Door Reader Board

Specifications

Door Control	Supports 1 OSDP reader; does not support Wiegand readers
Card Formats	8 active card formats per intelligent controller Entire card number reported on invalid read 19 digit (64-bit) User ID and 15 digit PIN numbers maximum PIV, CAC, and TWIC card compatible

General

Power Input	PoE (12.95 W) compliant to IEEE 802.3af or PoE+ (25 W) compliant to IEEE 802.3at or 12 Vdc \pm 10%, 1.7A maximum
Power Output	PoE: Locks and reader combined: 12 Vdc @ .66 A MAX PoE+ or 12 Vdc: Lock 12 Vdc @ 1 A MAX Readers: 12 Vdc @ .5 A MAX
Outputs	Four relays, Form-C contacts rated at 2 A @ 30 Vdc
Inputs	Six unsupervised/supervised, End of Line resistors, 1k/1k ohm, 1%, 1/4 watt standard

Reader Interface

Power	12 Vdc @ .5 A MAX
Communication	2-Wire RS-485, OSDP protocol, one device maximum

Cable Requirements

Ethernet	CAT-5, minimum
External Input Power	One twisted pair, 18 AWG (if required)
Alarm Inputs	One twisted pair per input, 30 ohm maximum
Relay Outputs	As required for the load
Reader Data RS-485/Power	Two twisted pair with shield, 24 AWG, 120 ohm impedance, 4000 foot (1220 m) MAX or RS-485: One twisted pair with shield, 24 AWG, 120 ohm impedance, 4000 foot (1220 m) MAX Power: 1 pair 18 AWG ¹

¹Type of cable(s) and gauge determined by length and voltage/current requirements. Local power source may be required.

Environmental

Temperature	-55 to 85 °C storage, 0 to 70 °C operating
Humidity	5 to 95% RHNC

Mechanical

Dimensions	5.5" (140 mm) W x 2.75" (70 mm) L x 0.96" (24 mm) H without bracket 5.5" (140 mm) W x 3.63" (92 mm) L x 1.33" (34 mm) H with bracket
-------------------	---

Compliance and Warranty

Product Compliance	UL294 Recognized ² , FCC Part 15 Class A, CE Compliant, RoHS, NIST Certified Encryption
---------------------------	--

² For UL, the Power Sourcing Equipment (PSE), such as a PoE or PoE+ enabled network switch and/or PoE or PoE+ power injectors, must be UL Listed under UL294B.

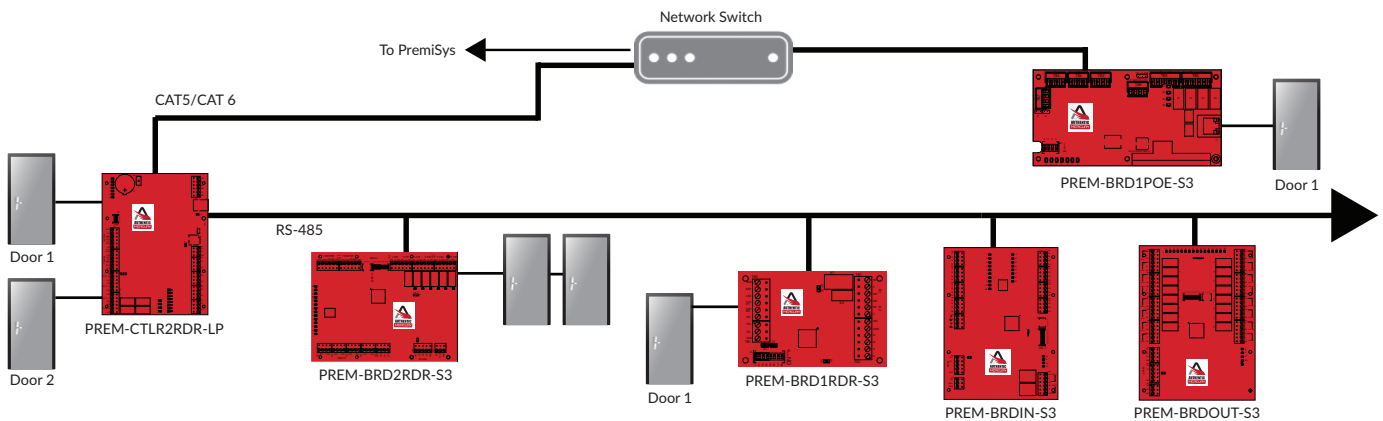

The Authentic Mercury open platform delivers quality assurance derived from the most proven and reliable hardware in the industry. Driven by our engineering excellence and technology leadership, Authentic Mercury hardware is designed as an access control platform that easily encompasses emerging technologies, changing industry standards and evolving system environments.

1041 Byers Road · Miamisburg, OH 45342

TEL 855.367.4721 or 800.562.8749 · www.matrixsys.com

All brand and product names mentioned may be trademarks or registered trademarks of their respective companies in the United States and/or other countries. See current PremiSys price list or other product documentation for warranties and limits of liability. Copyright © 2023 ACRE ®. All rights reserved. Rev. 4/23