

# MR51e Reader Interface

## Installation and Specifications

This device complies with part 15 of the FCC Rules. Operation is subject to the following two conditions: (1) This device may not cause harmful interference, and (2) this device must accept any interference received, including interference that may cause undesired operation.

### 1. General:

The MR51e reader interface provides a network connected interface to one physical barrier using single or paired reader. PoE based solution to the OEM integrator for interfacing TTL (D1/D0, Clock/Data), F/2F or RS-485 readers to door hardware. The on-board twisted pair Ethernet jack with PoE support enables easy installation. Two reader interfaces configured as paired or alternate readers provide control for one physical barrier.



Note: For UL, the Power Sourcing Equipment (PSE) such as a PoE enabled network switch and/or PoE power injectors must be UL Listed under UL294B.

Reader port 1 can accommodate a reader that utilizes TTL (D1/D0, Clock/Data), F/2F, or RS-485 device signaling and also provides tri-stated LED control, and buzzer control (one wire LED mode only).

Reader port 2 can accommodate a reader that TTL (D1/D0, Clock/Data), or F/2F signaling, and also provides tri-stated LED control, and buzzer control (one wire LED mode only). Two Form-C relay outputs may be used for door strike control or alarm signaling. The relay contacts are rated at 5 A @ 30 Vac/dc, dry contact configuration. Four inputs are provided that may be used for monitoring the door contacts, exit push buttons, and alarm contacts. Input circuits can be configured as unsupervised or supervised. The MR51e requires PoE or local 12 Vdc for power. The MR51e may be mounted in a 3-gang switch box; a mounting plate is supplied with the unit. The MR51e may be mounted in an enclosure; the supplied mounting plate has mounting holes that match the MR50 mounting footprint.

### 2. MR51e Hardware:

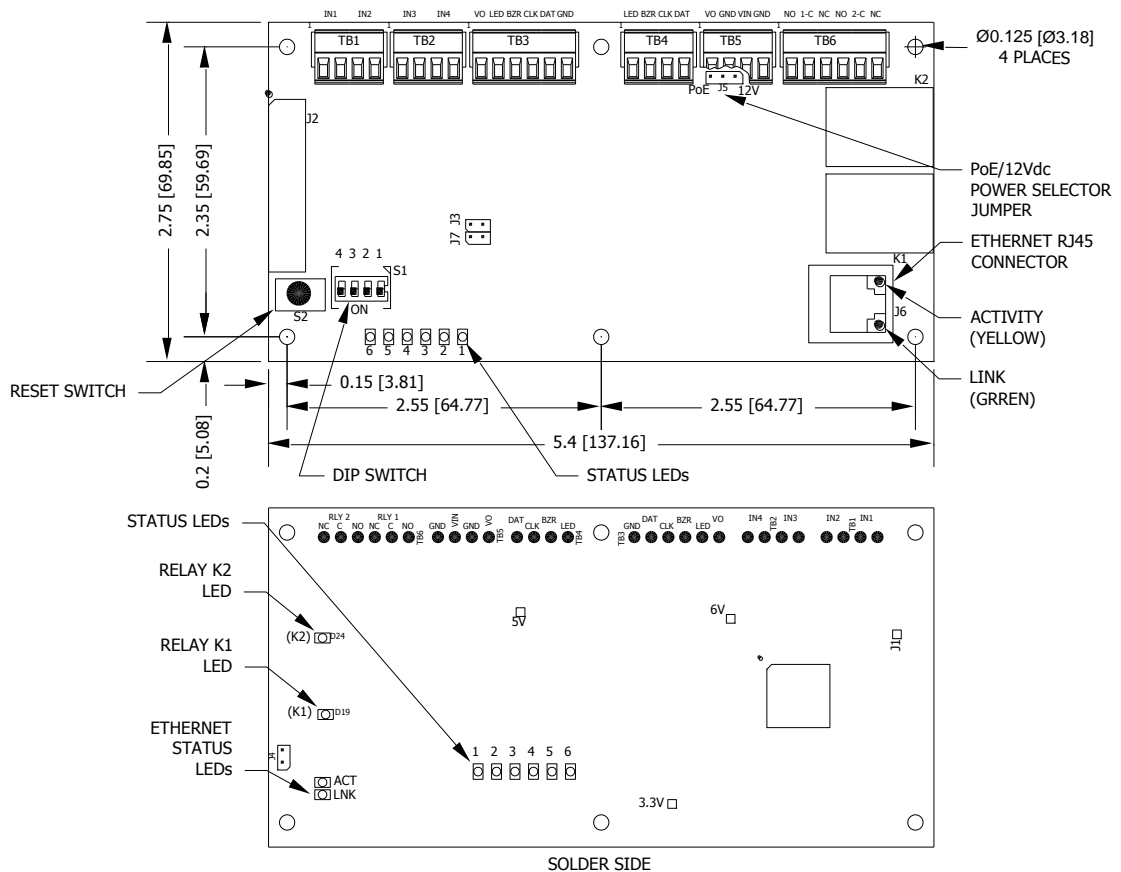

▪ **MR51e Terminal Blocks and Jumpers/Jacks:**

MR-51E CONNECTIONS		
TB1-1	IN1	Input 1
TB1-2		
TB1-3	IN2	Input 2
TB1-4		
TB2-1	IN3	Input 3
TB2-2		
TB2-3	IN4	Input 4
TB2-4		
TB3-1	VO	Reader 1 Power Output – 12 VDC
TB3-2	LED	Reader 1 LED Output
TB3-3	BZR	Reader 1 Buzzer Output
TB3-4	CLK	Reader 1 CLK/Data 1/TR+
TB3-5	DAT	Reader 1 DAT/Data 0/TR-
TB3-6	GND	Reader 1 Ground
TB4-1	LED	Reader 2 LED Output
TB4-2	BZR	Reader 2 Buzzer Output
TB4-3	CLK	Reader 2 CLK/Data 1 Input
TB4-4	DAT	Reader 2 DAT/Data 0 Input
TB5-1	VO	Auxiliary Power Output – 12 Vdc
TB5-2	GND	Auxiliary Power Output Ground
TB5-3	VIN	Input Power – 12 Vdc (from local power supply)
TB5-4	GND	Input Power Ground
TB6-1	NO	Relay K1 – Normally Open Contact
TB6-2	1-C	Relay K1 – Common Contact
TB6-3	NC	Relay K1 – Normally Closed Contact
TB6-4	NO	Relay K2 – Normally Open Contact
TB6-5	2-C	Relay K2 – Common Contact
TB6-6	NC	Relay K2 – Normally Closed Contact

**Jumpers:**

JUMPER	SET AT	DESCRIPTION
J1	N/A	Factory Use Only
J2	N/A	Factory Use Only
J3	N/A	Factory Use Only
J4	N/A	Factory Use Only
J5	PoE	MR-51E powered from the Ethernet connection
	12V	MR-51E powered from an external 12 Vdc power source connected to TB5-3 (VIN), TB5-4 (GND)
J6	N/A	Ethernet Connection with POE support
J7	N/A	Factory Use Only

### 3. DIP Switches:

The addressing mode used is determined by the DIP switch setting on the MR51e:

4	3	2	1	Addressing Mode Meaning
OFF	OFF	OFF	OFF	MSC-Specific DHCP (original method)
OFF	OFF	OFF	ON	Public DHCP
OFF	OFF	ON	OFF	Static IP
OFF	OFF	ON	ON	Programming Mode for Static IP Address Assignment
ON	ON	ON	ON	MSC-Specific DHCP (original method)

Notes:

- **Public DHCP and Static IP Addressing Modes are available with MR51e firmware revisions 1\_4\_2 and later**
- All other DIP switch settings are reserved for future use
- Press S2 to reset board after DIP switch is changed for new address mode

### 4. Input Power:

The MR51e is powered by one of two ways (jumper selected, J5):

- Power is supplied via the Ethernet connection using PoE, fully compliant to IEEE 802.3af
- Or local 12 Vdc power supply, TB5-3 (VIN), TB5-4 (GND).

### 5. Communication Wiring:

Communication between the EP controller and the MR51e is Ethernet (10Base T/100Base-TX). It is not recommended to connect the MR51e to a public intranet.

### 6. Reader Wiring:



Reader port 1 supports TTL (D1/D0, Clock/Data), F/2F, or 2-wire RS-485 device signaling. Reader port 2 supports TTL (D1/D0, Clock/Data), or F/2F signaling. Power to reader port 1 is 12 Vdc at 180 mA maximum. Reader port 2 may be powered from the auxiliary power supply output; TB5-1 and TB5-2. Readers that require different voltage or have high current requirements must be powered separately. Refer to the reader manufacture specifications for cabling requirements. In the 2-wire LED mode, the buzzer output is used to drive the second LED. Reader port configuration is set via the host software.



When powering any remote device(s) by the MR51e, care must be taken not to exceed the maximum current available. Cable gauge must also be evaluated. See specifications section for details.

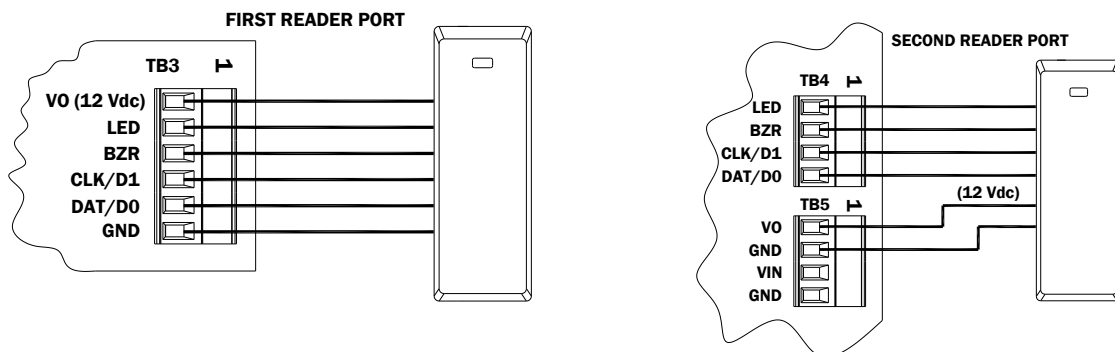

**Reader Port 1**  
Typical D1/D0 or Clock/Data Reader

**Reader Port 2**  
Typical D1/D0 or Clock/Data Reader

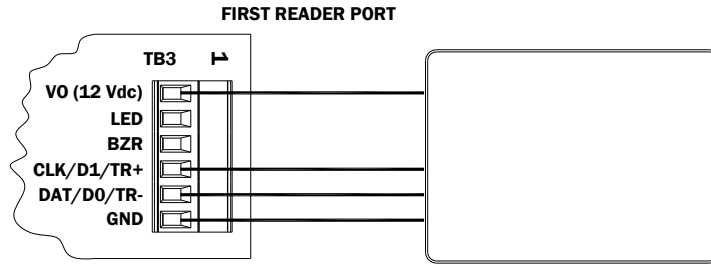

**Reader Port 1  
Typical 2-wire RS-485 Device**

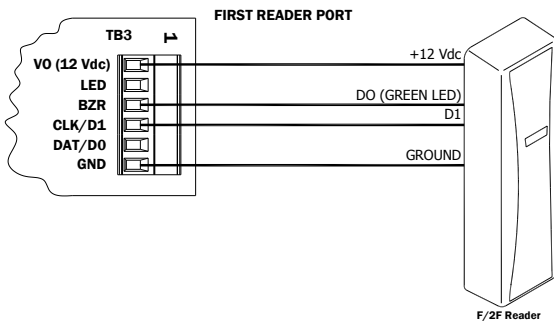

**Reader Port 1  
Typical Unsupervised F/2F Reader**

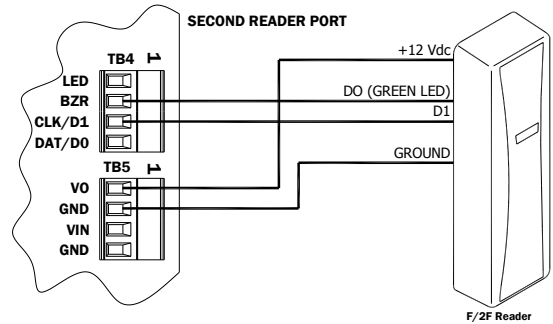

**Reader Port 2  
Typical Unsupervised F/2F Reader**

\* Inputs on supervised F/2F readers may be unsupervised or supervised (supervised shown).

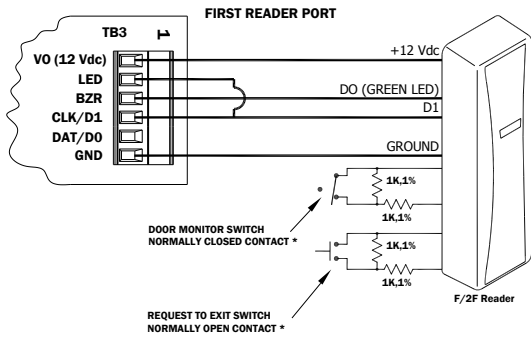

**Reader Port 1  
Typical Supervised F/2F Reader**

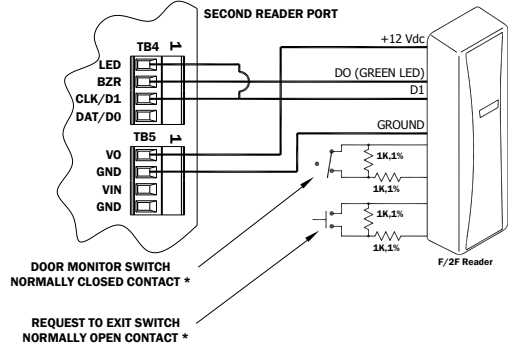

**Reader Port 2  
Typical Supervised F/2F Reader**

⚠ Jumper D1 and LED on supervised F/2F readers

## 7. Input Circuit Wiring:

Typically, these inputs are used to monitor door position, request to exit, or alarm contacts. Input circuits can be configured as unsupervised or supervised. When unsupervised, reporting consists of only the open or closed states.

When configured as supervised, the input circuit will report not only open and closed, but also open circuit, shorted, grounded\*, and foreign voltage\*. A supervised input circuit requires two resistors be added to the circuit to facilitate proper reporting. The standard supervised circuit requires 1K Ohm, 1% resistors and should be located as close to the sensor as possible. Custom end of line (EOL) resistances may be configured via the host software.

\* Grounded and foreign voltage states are not a requirement of UL 294 and therefore not verified by UL.

The input circuit wiring configurations shown are supported but may not be typical:

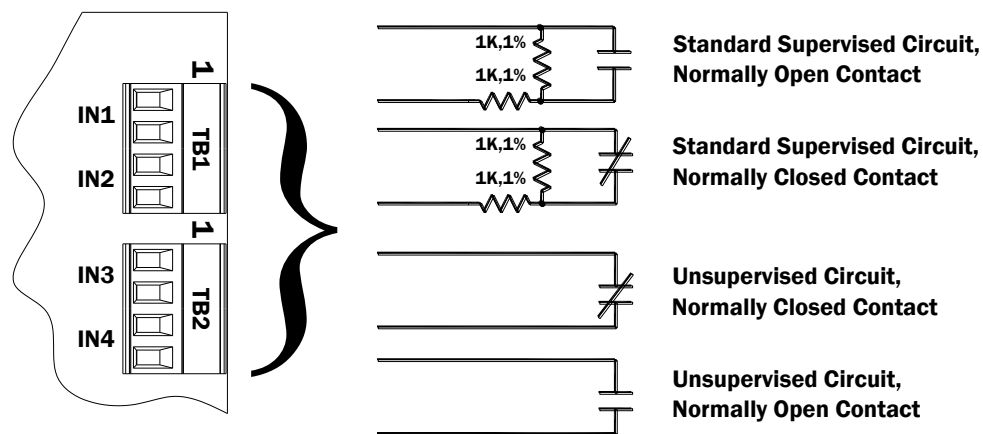

## 8. Relay Circuit Wiring:

Two Form-C contact relays are provided for controlling door lock mechanisms or alarm signaling. The relay contacts are rated at 5 A @ 30 Vac/dc, dry contact configuration. Each relay has a Common pole (C), a Normally Open pole (NO) and a Normally Closed pole (NC). When you are controlling the delivery of power to the door strike, the Normally Open and Common poles are used. When momentarily removing power to unlock the door, as with a mag lock, the Normally Closed and Common poles are used. Check with local building codes for proper egress door installation.

Door lock mechanisms can generate feedback to the relay circuit that can cause damage and premature failure of the relay. For this reason, it is recommended that either a diode or MOV (metal oxide varistor) be used to protect the relay. Wire should be of sufficient gauge to avoid voltage loss.



It is possible for the MR51e to provide power for a 12 Vdc door strike providing the maximum current is not exceeded, see specification section.

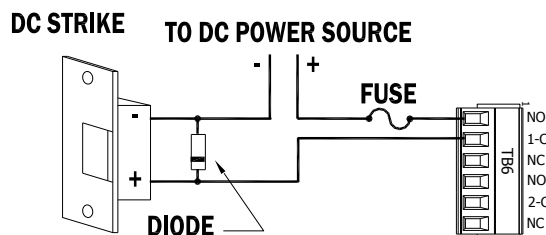

### Diode Selection:

Diode current rating: 1x strike count  
 Diode breakdown voltage: 4x strike voltage  
 For 12 Vdc or 24 Vdc strike, diode 1N4002 (100V/1A) typical.

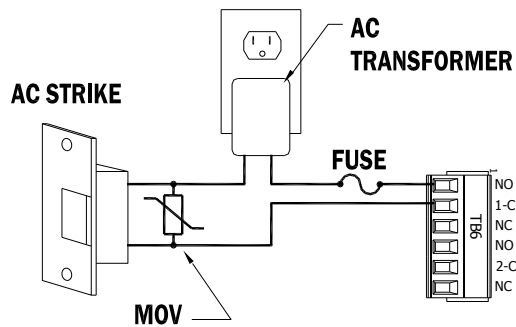

**MOV Selection:**

Clamp voltage: 1.5x Vac RMS.  
Use UL recognized MOV with appropriate ratings

**9. Status LEDs:**

At power up, LEDs 2 through 6 are turned ON then OFF in sequence.

After the above sequence has completed successfully, the MR51e goes to the “Waiting for IP Address” mode, when in the MSC-Specific DHCP or Public DHCP addressing modes:

Waiting for IP Address mode:

LED	DESCRIPTION
1	Off-line: 0.2 second ON, 0.8 second OFF
	Waiting for application firmware to be downloaded: .1 sec ON, .1 sec OFF
2	Waiting for IP address: 0.5 second ON, 0.5 second OFF

The following table describes the LED’s in the Normal Running mode. If communication is lost, the MR51e reverts back to the “Waiting for IP Address” mode, when in the MSC-Specific DHCP or Public DHCP addressing modes:

Normal Running mode:

LED	DESCRIPTION
1	On-line, encryption disabled = 0.8 second ON, 0.2 second OFF
	On-line, encryption enabled = four pulses; 0.1 second ON, 0.1 second OFF per second
	Off-line: 0.2 second ON, 0.8 second OFF (static addressing mode only)
	Waiting for application firmware to be downloaded: .1 sec ON, .1 sec OFF
2	Flashes when there is host communication (approximately every 5 seconds)
3	Flashes when data is received from either reader/downstream devices
4	Input IN1 Status: OFF = Inactive, ON = Active, Flashing = Trouble. See note 1
5	Input IN2 Status: OFF = Inactive, ON = Active, Flashing = Trouble. See note 1
6	Input IN3 Status: OFF = Inactive, ON = Active, Flashing = Trouble. See note 1
YEL	Ethernet speed: OFF = 10 Mb/S, ON = 100 Mb/S
GRN	OFF = No Link, ON = Good Link, Flashing = Ethernet Activity

Note 1: If this input is defined, every three seconds the LED is pulsed to its opposite state for 0.1 second, otherwise, the LED is off.

## 10. Specifications:

The interface is for use in low voltage, Class 2 circuits only.

Power Input:	PoE Power Input 12.95 W, compliant to IEEE 802.3af – OR – 12 Vdc $\pm$ 10 %, 900 mA maximum
Power Output:	12 Vdc @ 650 mA maximum (reader and AUX outputs combined) Reader (TB3) 12 Vdc (10.3 through 12.6) @ 180 mA maximum AUX (TB5) 12 Vdc (10.7 through 13.0) @ 650 mA maximum



Note: For UL, the Power Sourcing Equipment (PSE) such as a PoE enabled network switch and/or PoE power injectors must be UL Listed under UL294B.

Output:	Two relays, Form-C contacts rated at 5 A @ 30 Vac/dc
Inputs:	Four unsupervised/supervised, End of Line resistors, 1k/1k ohm, 1%, ¼ watt standard

### Reader Interface:

Power:	See Power Output above.
LED Output:	TTL compatible, high > 3 V, low < 0.5 V, 5 mA source/sink maximum
Buzzer Output:	Open collector, 12 Vdc open circuit maximum, 40 mA sink maximum
Data Inputs:	Reader port 1: TTL compatible, F/2F or 2-wire RS-485 Reader port 2: TTL compatible or F/2F

### Cable Requirements:

Communication:	Ethernet, Category 5, minimum
Power:	1 twisted pair, 18 AWG
Alarm Inputs:	1 twisted pair per input, 30 ohm maximum
Reader data (TTL):	6-conductor, 18 AWG, 500 ft. (152 m) maximum
Reader data (F/2F)	4-conductor, 18 AWG, 500 ft. (152 m) maximum
Reader data (RS-485):	1 twisted pair with drain wire and shield, 24 AWG, 120 ohm impedance 2000 foot (610 m) maximum

### Environment:

Temperature:	-55 to +85 °C, storage 0 to +70 °C, operating
Humidity:	5 to 95 % RHNC

### Mechanical:

Dimension:	5.5 in. (140 mm) W x 2.75 in. (70 mm) L x 0.96 in. (24 mm) H without bracket 5.5 in. (140 mm) W x 3.63 in. (92 mm) L x 1.33 in. (34 mm) H with bracket
Weight:	4.2 oz. (120 g) without bracket 5.3 oz. (150 g) with bracket

## 11. Additional Mounting Information:

Sources for the optional items shown below:

- 3-gang stainless steel blank cover. Available from:  
Leviton part number 84033-40  
Graybar part number 88158404
- Magnetic switch set: G.R.I. part number: 505

### Side View:

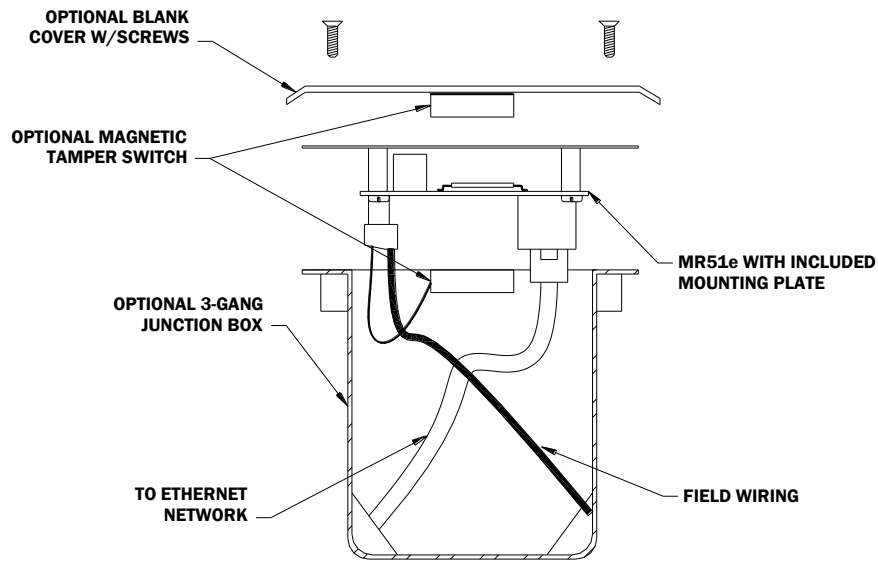

### Mounting Plate Dimensions:

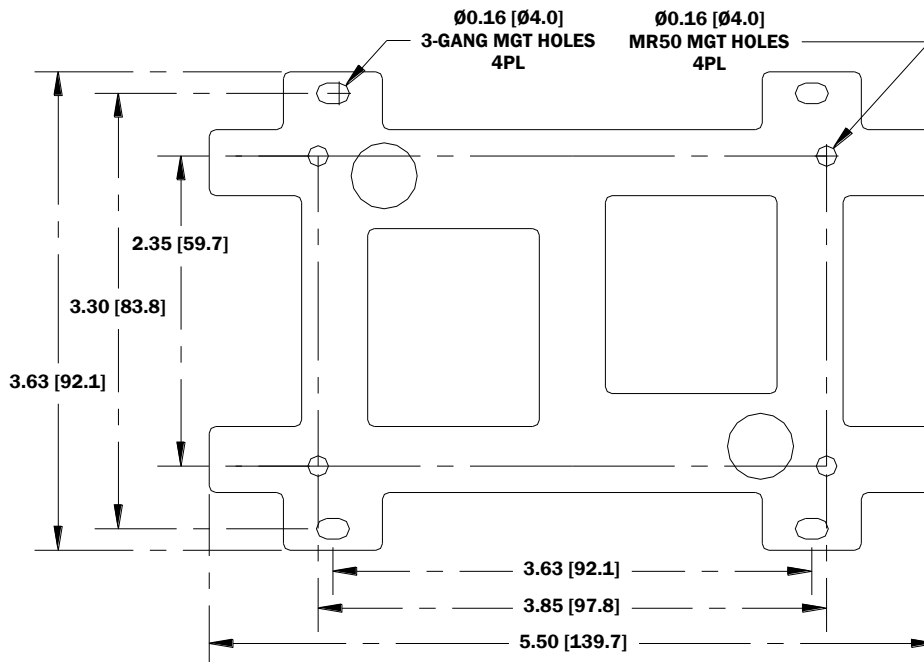



## **Warranty**

Mercury Security warrants the product is free from defects in material and workmanship under normal use and service with proper maintenance for one year from the date of factory shipment. Mercury Security assumes no responsibility for products damaged by improper handling or installation. This warranty is limited to the repair or replacement of the defective unit.

There are no expressed warranties other than set forth herein. Mercury Security does not make, nor intends, nor does it authorize any agent or representative to make any other warranties, or implied warranties, and expressly excludes and disclaims all implied warranties of merchantability or fitness for a particular purpose.

All returns must be accompanied by a Return Material Authorization (RMA) number obtained from customer service, and prepaid postage and insurance.

## **Liability**

The Interface should only be used to control exits from areas where an alternative method for exit is available. This product is not intended for, nor is rated for operation in life-critical control applications. Mercury Security is not liable under any circumstances for loss or damage caused by or partially caused by the misapplication or malfunction of the product. Mercury Security's liability does not extend beyond the purchase price of the product.