



HID Mercury™ LP4502 Controller

Installation and Specifications

PLT-05246, A.4
June 2021

Powering
Trusted Identities

Copyright

© 2020 - 2021 HID Global Corporation/ASSA ABLOY AB. All rights reserved.

This document may not be reproduced, disseminated or republished in any form without the prior written permission of HID Global Corporation.

Trademarks

HID GLOBAL, HID, the HID Brick logo, the Chain Design, and HID Mercury are trademarks or registered trademarks of HID Global, ASSA ABLOY AB, or its affiliate(s) in the US and other countries and may not be used without permission. All other trademarks, service marks, and product or service names are trademarks or registered trademarks of their respective owners.

Contacts

HID Global Technical Support: www.hidglobal.com/support.

Americas and Corporate	Asia Pacific
611 Center Ridge Drive Austin, TX 78753 USA Phone: +1 866 607 7339	19/F 625 King's Road North Point, Island East Hong Kong Phone: +852 3160 9833
Europe, Middle East, and Africa (EMEA)	Brazil
3 Cae Gwyrdd Green Meadow Springs Cardiff CF15 7AB United Kingdom Phone: +44 (0) 1440 711 822	Condomínio Business Center Av. Ermano Marchetti, 1435 Galpão A2 - CEP 05038-001 Lapa - São Paulo / SP Brazil Phone: +55 11 5514-7100

For additional offices around the world, see www.hidglobal.com/contact/corporate-offices.

What's new

Date	Description	Revision
June 2021	Minor updates.	A.4

A complete list of revisions is available in [Revision history](#).

Section **01**

Overview

1.1 LP4502 Intelligent controller with two reader interfaces

The LP4502 intelligent controller provides decision making, event reporting, and database storage for the HID Mercury hardware platform. Two reader interfaces provide control for two doors.

Host communication is via the on-board 10Base T/100Base-TX Ethernet port, or the Micro USB port (2.0) with an optional Micro USB to Ethernet adapter.

Two physical barriers can be controlled with the LP4502. Each reader port can accommodate a read-head that utilizes TTL (D1/DO, Clock/Data), F/2F or 2-wire RS-485 electrical signaling (OSDP reader for example) and also provides tri-state LED control and buzzer control (one wire LED mode only).

Four Form-C relay outputs are provided for door strike control or alarm signaling.

Eight inputs are provided for monitoring the door contacts, exit push buttons, and alarm contacts. Input circuits can be configured as unsupervised or supervised.

The LP4502 requires 12 to 24 V DC for power.

1.2 LP4502 hardware

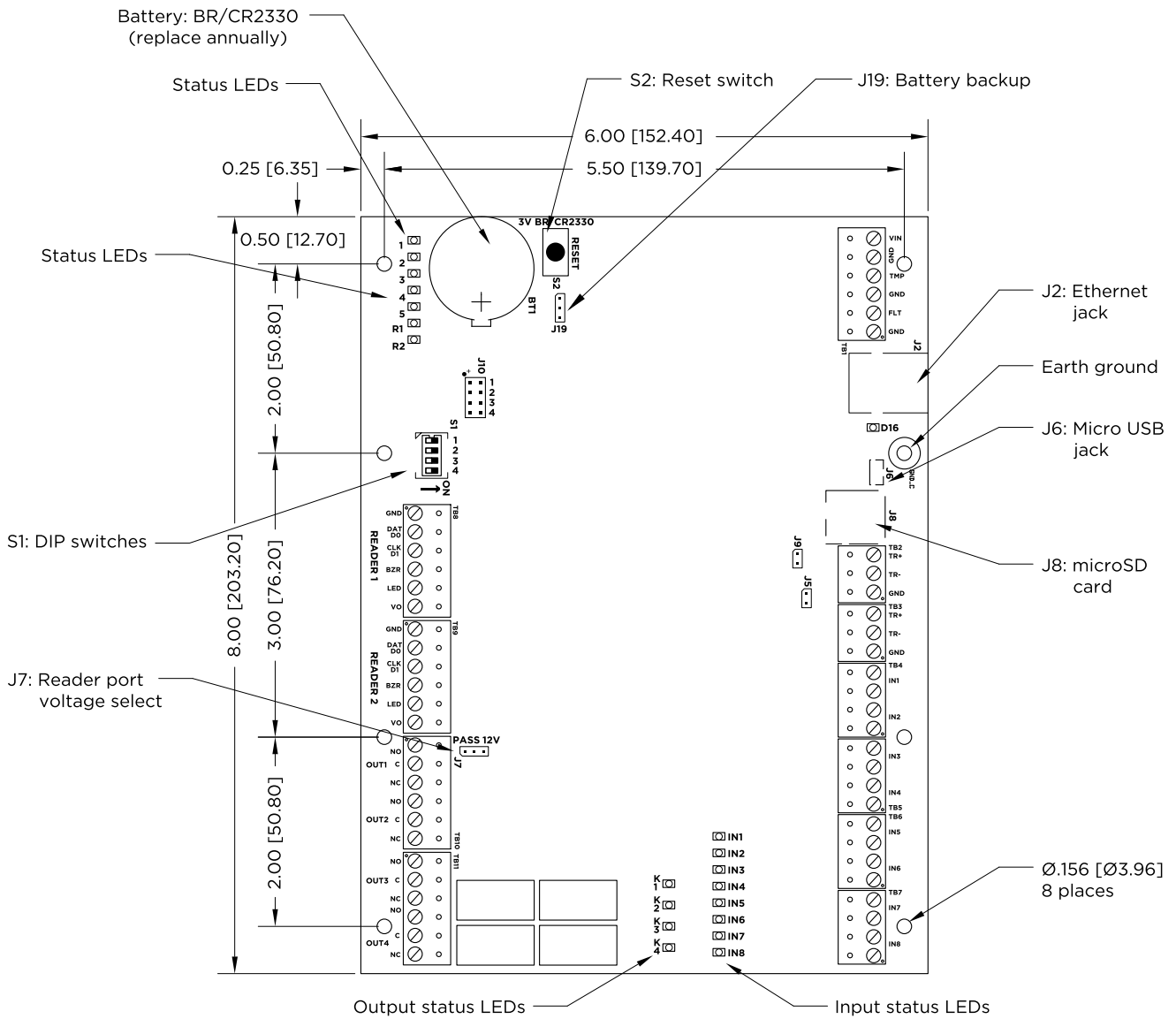

Section **02**

LP4502 wiring and setup

2.1 LP4502 connections

TB1-1	GND	Power fault input
TB1-2	FLT	
TB1-3	GND	Cabinet Tamper input
TB1-4	TMP	
TB1-5	GND	Power input
TB1-6	VIN: 12 to 24 V DC	

TB2-1	GND	SIO port 1 (2-wire RS-485)
TB2-2	TR- (A) ¹	
TB2-3	TR+ (B) ¹	
TB3-1	GND	SIO port 2 (2-wire RS-485)
TB3-2	TR- (A) ¹	
TB3-3	TR+ (B) ¹	

TB4-1	IN2	Input 2
TB4-2	IN2	
TB4-3	IN1	Input 1
TB4-4	IN1	

TB5-1	IN4	Input 4
TB5-2	IN4	
TB5-3	IN3	Input 3
TB5-4	IN3	

TB6-1	IN6	Input 6
TB6-2	IN6	
TB6-3	IN5	Input 5
TB6-4	IN5	

TB7-1	IN8	Input 8
TB7-2	IN8	
TB7-3	IN7	Input 7
TB7-4	IN7	

TB8-1	GND	Reader 1 - Ground
TB8-2	DAT/D0	Reader 1 - Data/Data 0/TR- (A) ¹
TB8-3	CLK/D1	Reader 1 - Clock/Data 1/TR+ (B) ¹
TB8-4	BZR	Reader 1 - Buzzer
TB8-5	LED	Reader 1 - LED
TB8-6	VO	Reader 1 - Power

TB9-1	GND	Reader 2 - Ground
TB9-2	DAT/D0	Reader 2 - Data/Data 0/TR- (A) ¹
TB9-3	CLK/D1	Reader 2 - Clock/Data 1/TR+ (B) ¹
TB9-4	BZR	Reader 2 - Buzzer
TB9-5	LED	Reader 2 - LED
TB9-6	VO	Reader 2 - Power

TB10-1	NO	Out 1 - Normally open contact
TB10-2	C	Out 1 - Common
TB10-3	NC	Out 1 - Normally closed contact
TB10-4	NO	Out 2 - Normally open contact
TB10-5	C	Out 2 - Common contact
TB10-6	NC	Out 2 - Normally closed contact

TB11-1	NO	Out 3 - Normally open contact
TB11-2	C	Out 3 - Common contact
TB11-3	NC	Out 3 - Normally closed contact
TB11-4	NO	Out 4 - Normally open contact
TB11-5	C	Out 4 - Common contact
TB11-6	NC	Out 4 - Normally closed contact

1. Terms A & B are from the RS-485 standard.

2.1.1 Jumpers and jacks

The LP4502 processor hardware interface is configured using jumpers to setup the reader port power and end of line termination.

Jumpers	Set at	Description
J2	N/A	10 Base-T/100Base-Tx Ethernet connection (Port 0).
J5	OFF	Port 2 RS-485 EOL terminator is OFF.
	ON	Port 2 RS-485 EOL terminator is ON.
J7	Reader power select. See caution below.	
	12V	12 V DC at reader ports.
	PASS	VIN "Pass Through" to reader ports.
J6	N/A	Micro USB port (2.0)
J8	N/A	microSD card
J9	OFF	Port 1 RS-485 EOL terminator is OFF.
	ON	Port 1 RS-485 EOL terminator is ON.
J10-1	N/A	Remote Status LED #1. ¹
J10-2	N/A	Remote Status LED #2. ¹
J10-3	N/A	Remote Status LED #3. ¹
J10-4	N/A	Remote Status LED #4. ¹
J19	OFF	Backup battery is OFF.
	ON	Backup battery is ON. See Memory and real time clock backup battery

1. Observe polarity connection to LED. External current limiting is not required.



Caution: Install jumper J7 in the 12 V position **ONLY** if the input voltage (VIN) is greater than 20 V DC. Failure to do so may damage the reader or LP4502.

2.1.2 DIP switches

The four switches on S1 DIP switch configure the operating mode of the LP4502 processor.

DIP switches are read on power-up except where noted. Pressing reset switch S2 causes the LP4502 to reboot.

1	2	3	4	Definitions
OFF	OFF	OFF	OFF	Normal operating mode.
ON	X	OFF	OFF	After initialization, enable default User Name (admin) and Password (password). The switch is read on the fly, a re-boot is not required. See IT security for additional information.
OFF	ON	OFF	OFF	Use factory default communication parameters.
ON	ON	OFF	OFF	Use OEM default communication parameters. Contact system manufacture for details. See Bulk erase configuration memory .
ON	ON	OFF	OFF	Bulk Erase prompt mode at power up. See Bulk erase configuration memory .
X	X	X	ON	Makes the LP4502 report and function like an EP4502. To be used in situations where the host software has not been updated to support the LP series product line.

Note: All other switch settings are unassigned and are reserved for future use. X = don't care.



Caution: In the factory or OEM default modes, downloaded configuration/database is not saved to flash memory.

2.2 Factory default communication parameters

Interface 1 (NIC1)

Network: static IP address	192.168.0.251
Subnet mask	255.255.0.0
Default gateway	192.168.0.1
DNS server	192.168.0.1
Primary host port	IP server, Data security: TLS if Available, port 3001, communication address: 0
Alternate host port	Disabled

2.3 Bulk erase configuration memory

The bulk erase function can be used for the following:

- Erase all configuration and cardholder database (sanitize board, less third party applications).
- Update OEM default parameters after OEM code has been changed.
- Recover from database corruption causing the LP4502 board to continuously reboot.

Note: If clearing the memory does not correct the initialization problem, contact Tech Support (TechSupport@Mercury-Security.com).

2.3.1 Bulk erase steps

1. Set S1 DIP switches 1 and 2 to **ON**, and 3 and 4 to **OFF**.
2. Apply power to the LP4502 board. LED 1 is on for about 15 seconds while LP4502 boots up.
3. Change DIP switches 1 or 2 to **OFF** Within 10 seconds after LEDs 1 and 2, and LEDs 3 and 4 start flashing alternately at a rate of 0.5 seconds. If these switches are not changed, the LP4502 board will power up using the OEM default communication parameters.
4. LED 2 will flash indicating that the configuration memory is being erased. Full memory erase takes up to 60 seconds.
5. When complete, only LEDs 1 and 4 will flash for about three seconds.
6. The LP4502 board will complete its initialization within two seconds after LEDs 1 and 4 stop flashing.



Caution: Do not remove power during the bulk erase process.

2.4 Input power, cabinet tamper and UPS fault input wiring

The LP4502 requires 12-24 V DC power. Locate power source as close to the unit as possible.

Connect power with minimum of 18 AWG wire. Connect the GND signal to earth ground in only ONE LOCATION within the system! Multiple earth ground connections may cause ground loop problems and is not advised.

Observe POLARITY on 12-24 V DC input!

There are two dedicated inputs for cabinet tamper and UPS fault monitoring. Normal (safe) condition is a closed contact. If these inputs are not used, install a jumper wire.

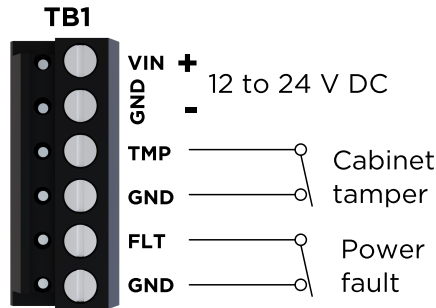

2.5 Communication wiring

The LP4502 controller communicates with the host via the on-board Ethernet 10-BaseT/100Base-TX port and/or the Micro USB port (2.0) with an optional Micro USB to Ethernet adapter.

The serial I/O device communication ports, TB2 for port 1 and TB3 for port 2, are 2-wire RS-485 interface which can be used to connect additional I/O panels. The interface allows multi-drop communication on a single bus of up to 4,000 feet (1,219 m). Use 1-twisted pair, shielded cable, 120Ω impedance, 24 AWG, 4,000 ft. (1,219 m) maximum for communication.



Caution: Install the termination jumper **ONLY** on the panel at each end of the RS-485 bus. Failure to do so will compromise the proper operation of the communication channel.

Port 1 to serial I/O devices

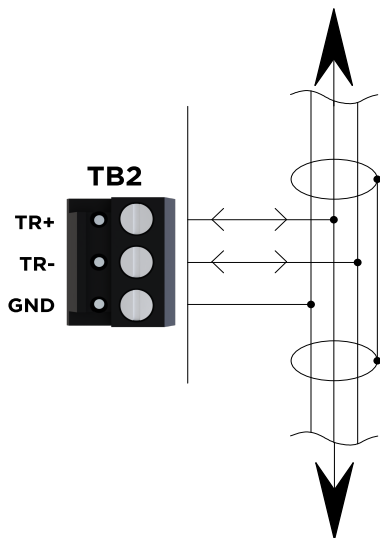

Port 2 to serial I/O devices

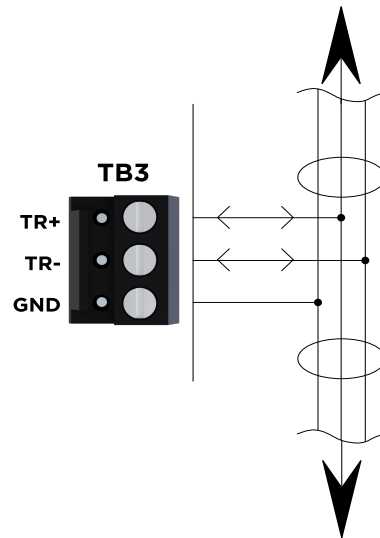

2.6 Reader wiring

Each reader port supports a reader with TTL (D1/D0, Clock/Data), F/2F (standard or supervised), or 2-wire RS-485 signaling (OSDP reader for example). Power to the reader is selectable: 12 V DC (VIN must be greater than 20 V DC), or power is passed-through (PASS) from the input voltage of the LP4502 (TB1-VIN) and is current limited to 300 mA for each reader port. Readers that require different voltage or have high current requirements should be powered separately. Refer to the reader manufacture specifications for cabling requirements. In the 2-wire LED mode the Buzzer output is used to drive the second LED. Reader port configuration is set via the host software. Do not terminate any RS-485 devices connected to a reader port.



To fully utilize each reader port:

- TTL signaling requires a 6-conductor cable (18 AWG)
- F/2F signaling requires a 4-conductor cable
- RS-485 signaling requires two 2-conductor cables. Use one cable for power (18 AWG, 1-pair) and one cable for communication (24 AWG, 1-pair, shielded)

Note: For OSDP cable lengths greater than 200 ft (61 m) or EMF interference, install 120Ω +/- 2Ω resistor across RS-485 termination ends.

Note: Data 0 and Data 1 wires for Wiegand may be reused for OSDP. However, standard Wiegand cable may not meet RS-485 twisted pair recommendations. The reuse of cable works best on shorter cable lengths at lower data rates.

J7 – Reader power select

12V PASS	Reader power
	12 V DC is available on reader ports (VIN > 20 V DC)
	VIN power is "passed through" to reader ports



Caution: Install jumper J7 in the 12V position **ONLY** if the input voltage (VIN) is greater than 20 V DC. Failure to do so may damage the reader or LP4502.

Input power	Reader power select	Reader output	Notes
24 V DC	Pass-through	24 V DC	
24 V DC	12 V DC	12 V DC	
12 V DC	Pass-through	12 V DC	
12 V DC	12 V DC	0 V DC	Caution: Do not use

Typical reader 1 (OSDP installation)

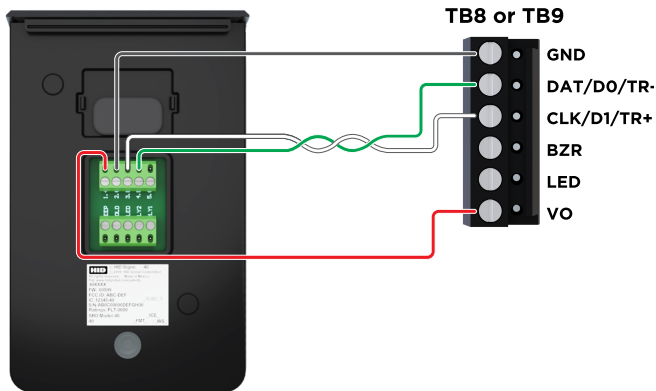

Typical reader 1 (Wiegand or Clock/Data installation)

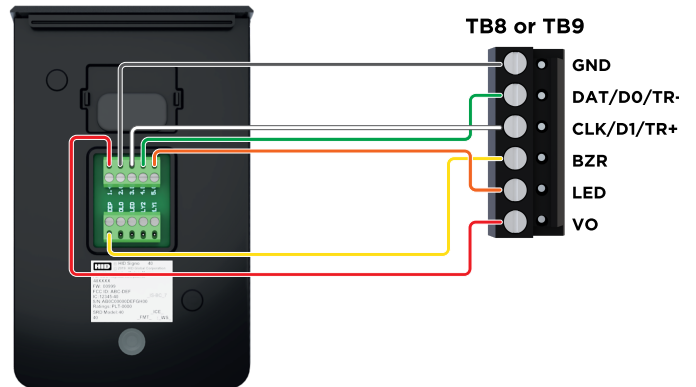

Typical reader 2 (OSDP installation)

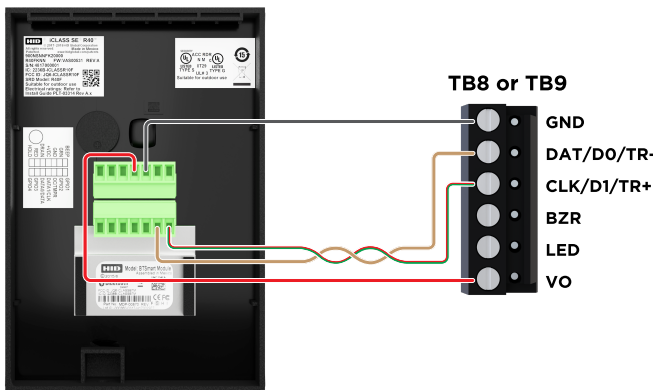

Typical reader 2 (Wiegand or Clock/Data installation)

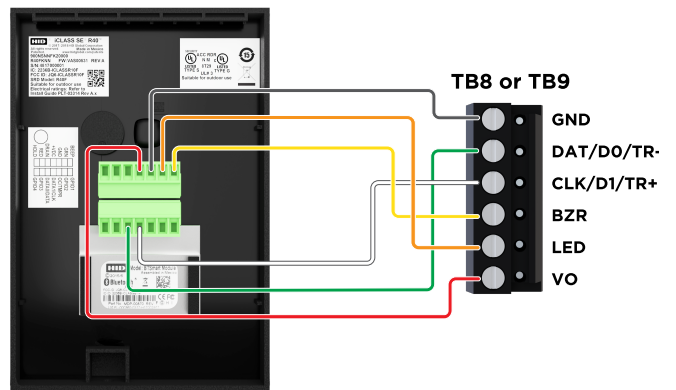

Typical unsupervised F/2F reader

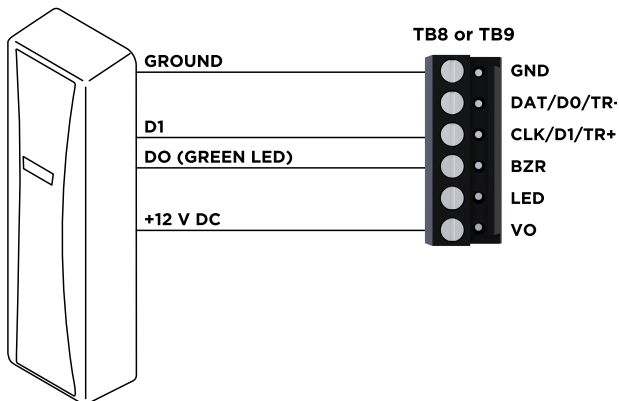

Typical supervised F/2F reader

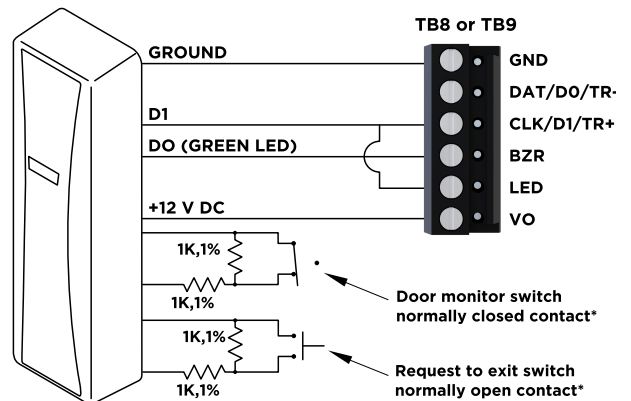

Jumper D1 to LED on supervised F/2F reader

2.7 Input circuit wiring

There are eight inputs that are typically used to monitor door position, request to exit, or alarm contacts. Input circuits can be configured as unsupervised or supervised. When unsupervised, reporting consists of only the open or closed states. When configured as supervised, the input circuit will report not only open and closed, but also open circuit, shorted, grounded*, and foreign voltage*. A supervised input circuit requires two resistors be added to the circuit to facilitate proper reporting. The standard supervised circuit requires 1kΩ, 1% resistors and should be located as close to the sensor as possible. Custom end of line (EOL) resistances may be configured via the host software.

*Grounded and foreign voltage states are not a requirement of UL 294 and therefore not verified by UL.

The input circuit wiring configurations shown are supported but may not be typical:

**Terminal blocks
TB4 through TB7**

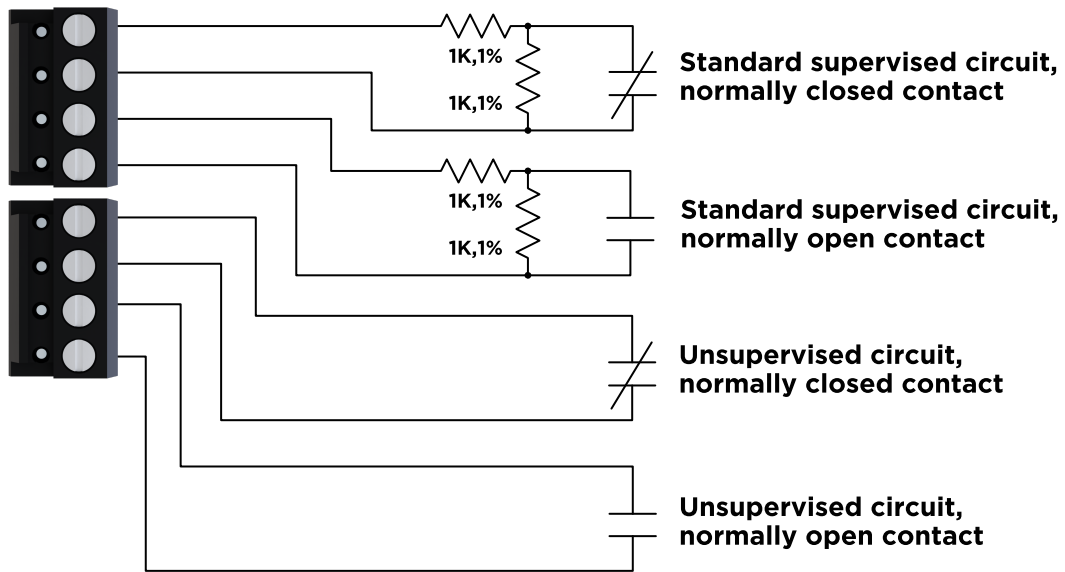

2.8 Relay circuit wiring

Four relays with Form-C contacts (dry) are provided for controlling door lock mechanisms or alarm signaling. Each relay has a Common pole (**C**), a Normally Open pole (**NO**) and a Normally Closed pole (**NC**). When controlling the delivery of power to the door strike, the Normally Open and Common poles are typically used. When momentarily removing power to unlock the door, as with a mag lock, the Normally Closed and Common poles are typically used. Check with local building codes for proper egress door installation.

Door lock mechanisms can generate feedback to the relay circuit that can cause damage and premature failure of the relay, and affect the operation of the LP4502. For this reason, it is recommended that a diode is used to protect the relay. Wire should be of sufficient gauge to avoid voltage loss.

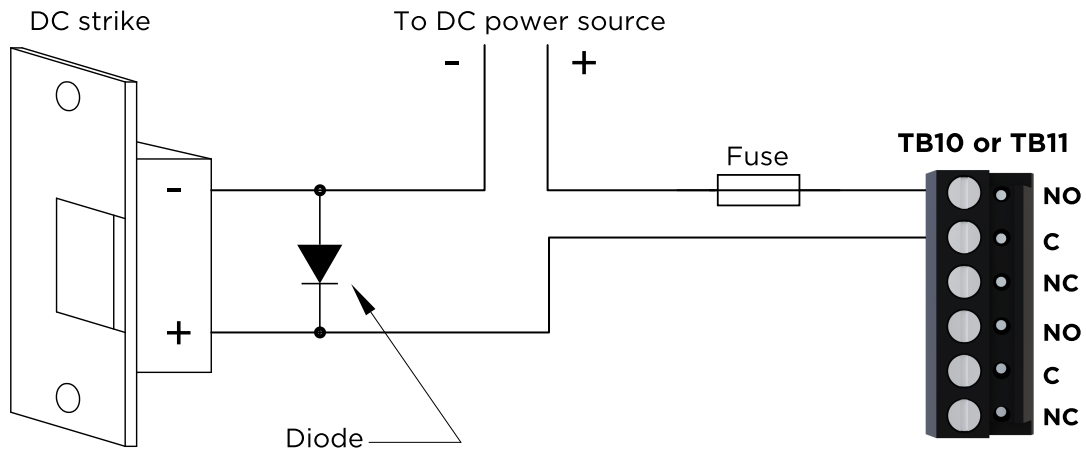

Diode selection

- Diode current rating: 1x strike current.
- Diode breakdown voltage: 4x strike voltage.
- For 12 V DC or 24 V DC strike, diode 1N4002 (100V/1A) typical.

2.9 Memory and real time clock backup battery

The static RAM and the real time clock are backed up by a lithium battery when input power is removed. This battery should be replaced annually. If data in the static RAM is determined to be corrupt after power up, all data, including flash memory, is considered invalid and is erased. All configuration data must be re-downloaded.

During installation and while the unit is not powered, change the jumper position (J19) from **OFF** to **ON** to enable the battery backup.

Battery type: BR2330 or CR2330.

2.10 Status LEDs

2.10.1 Power-up

All LEDs are OFF.

2.10.2 Initialization

After power is applied or reset switch pushed, LED 1 is ON for about 15 seconds, then LEDs 2, 3, 4, 5, 6, R1, R2, IN1, IN2, IN3, IN4, IN5, IN6, IN7 and IN8 are flashed once at the beginning of initialization. LEDs 3 and 4 is turned ON for approximately 1 second after the hardware initialization has completed, then the application code is initialized. The amount of time the application takes to initialize depends on the size of the database, about 1 second without a card database. Each 10,000 cards will add about 2 seconds to the application initialization. When LEDs 1, 2, 3 and 4 flash at the same time, data is being read from or written to flash memory, do not cycle power when in this state. If the sequence stops or repeats, perform the bulk erase procedure, see [Bulk erase configuration memory](#).

2.10.3 Running

After initialization is complete, the LEDs have the following meanings:

LED	Description
1	Off-line / On-line and battery status
	Off-line = 20% ON, On-line = 80% ON
	Double flash if battery is low
2	Host communication activity (Ethernet)
3	Internal SIO communication activity
4	External SIO communication activity (Port 1)
5	External SIO communication activity (Port 2)
R1	Reader 1: Clock/Data or D1/D0 Mode = Flashes when data is received, either input. F/2F mode: Flashes when data/acknowledgment is received RS-485 mode = Flashes when transmitting data
R2	Reader 2: Clock/Data or D1/D0 Mode = Flashes when data is received, either input. F/2F mode: Flashes when data/acknowledgment is received RS-485 mode = Flashes when transmitting data
YEL	Ethernet speed: OFF = 10Mb/S, ON = 100Mb/S
GRN	OFF = No link, ON = Good link, Flashing = Ethernet activity
D16	Ethernet activity
IN1	Input IN1 status: OFF = Inactive, ON = Active, Flash = Fault ¹
IN2	Input IN2 status: OFF = Inactive, ON = Active, Flash = Fault ¹
IN3	Input IN3 status: OFF = Inactive, ON = Active, Flash = Fault ¹
IN4	Input IN4 status: OFF = Inactive, ON = Active, Flash = Fault ¹
IN5	Input IN5 status: OFF = Inactive, ON = Active, Flash = Fault ¹
IN6	Input IN6 status: OFF = Inactive, ON = Active, Flash = Fault ¹
IN7	Input IN7 status: OFF = Inactive, ON = Active, Flash = Fault ¹

LED	Description
IN8	Input IN8 status: OFF = Inactive, ON = Active, Flash = Fault ¹
K1	Relay K1: ON = Energized
K2	Relay K2: ON = Energized
K3	Relay K3: ON = Energized
K4	Relay K4: ON = Energized

1. If this input is defined, every three seconds the LED is pulsed to its opposite state for 0.1 seconds, otherwise, the LED is off.

2.11 IT security

Ensure that the LP4502 is installed securely. Create user accounts to the web configuration page using secure passwords.

Ensure all DIP switches are to be in the **OFF** position for the normal operating mode.

The LP4502 is shipped from the factory with a default login account, which is enabled when DIP 1 is moved from **OFF** to **ON** (See [DIP switches](#)). The default login user name (admin) and password (password) will be available for five minutes once the DIP switch is toggled. It is therefore important that at least one user account is defined, and the DIP switches are set to **OFF** before the LP4502 is commissioned.

Configuring the LP4502 with an IP address that is accessible from the public is **not** recommended.

The following options are available for enhanced network security:

- Disable SNMP.
- Zeroconf discovery.
- The web configuration module.
- Enable data encryption over the host communication port.

Section **03**

Specifications

The LP4502 is for use in low voltage, Class 2 Circuits only

The installation of this device must comply with all local fire and electrical codes.

Primary power	12 to 24 V DC \pm 10 %, 550 mA maximum (reader and USB current not included)
Reader ports	600 mA maximum (add 600 mA to primary power current)
Micro USB port	5 V DC, 500 mA maximum (add 270 mA to primary power current)
Memory and clock backup battery	3 Volt Lithium, type BR2330 or CR2330
microSD card	Format: microSD or microSDHC; 2GB to 8GB.
Host communication	Ethernet: 10Base T/100Base-TX and micro USB port (2.0) with optional adapter: pluggable model USB2-OTGE100
Serial I/O device	Two each: 2-wire RS-485, 2,400 to 115,200 bps, asynchronous, half-duplex, 1 start bit, 8 data bits, and 1 stop bit
Inputs	Eight unsupervised/supervised, standard EOL: 1k/1k Ω , 1%, ¼ watt
	Two unsupervised dedicated for cabinet tamper and UPS fault monitoring
Output	Four relays, Form-C with dry contacts
	Normally open contact (NO): 5 A @ 30 V DC resistive
	Normally closed contact (NC): 3 A @ 30 V DC resistive

Reader interface	
Power (jumper selectable)	12 V DC \pm 10% regulated, 300 mA maximum each reader (input voltage (VIN) must be greater than 20 V DC)
	or
	12 to 24 V DC \pm 10% (input voltage (VIN) passed through), 300 mA maximum each reader
Data inputs	TTL compatible, F/2F or 2-wire RS-485
RS-485 mode	9,600 to 115,200 bps, asynchronous, half-duplex, 1 start bit, 8 data bits, and 1 stop bit. Maximum cable length: 2000 ft. (609.6 m)
LED output	TTL levels, high>3 V, Low<0.5 V, 5 mA source/sink maximum
Buzzer output	Open collector, 12 V DC open circuit maximum, 40 mA sink maximum

Cable requirements	
Power and relays	1 twisted pair, 18 to 16 AWG
Ethernet	CAT-5, minimum
Reader data (TTL)	6-conductor, 18 AWG, 500 feet (150 m) maximum
Reader data (F/2F)	4-conductor, 18 AWG, 500 feet (150 m) maximum
Reader data (RS-485)	1 twisted pair, shielded. 24 AWG, 120 Ω impedance, 2,000 feet (610 m) maximum
RS-485 I/O devices	1 twisted pair, shield. 120 Ω impedance, 24 AWG, 4,000 ft. (1,219 m) maximum
Alarm input	1 twisted pair, 30 Ω maximum, typically 22 AWG @ 1000 ft. (304.8 m)

Environmental	
Storage temperature	-55 to +85°C
Operating temperature	0 to +70°C
Humidity	5 to 95% RHNC

Mechanical	
Dimension	8 inches (203.2 mm) W x 6 inches (152.4 mm) L x 1 inches (25 mm) H
Weight	10.65 oz. (302 g) nominal, board only

UL294, 6th edition Performance Levels

Feature	Level
Standby Power	I
Endurance	IV
Line Security	I
Destructive Attack	I

These specifications are subject to change without notice.

3.1 Warranty

Mercury Security warrants the product is free from defects in material and workmanship under normal use and service with proper maintenance for one year from the date of factory shipment. Mercury Security assumes no responsibility for products damaged by improper handling or installation. This warranty is limited to the repair or replacement of the defective unit.

There are no expressed warranties other than set forth herein. Mercury Security does not make, nor intends, nor does it authorize any agent or representative to make any other warranties, or implied warranties, and expressly excludes and disclaims all implied warranties of merchantability or fitness for a particular purpose.

Returns must be accompanied by a Return Material Authorization (RMA) number obtained from customer service, and prepaid postage and insurance.

3.2 Liability

The Interface should only be used to control exits from areas where an alternative method for exit is available. This product is not intended for, nor is rated for operation in life-critical control applications. Mercury Security is not liable under any circumstances for loss or damage caused by or partially caused by the misapplication or malfunction of the product. Mercury Security’s liability does not extend beyond the purchase price of the product.

3.3 Regulatory

This device complies with part 15 of the FCC Rules. Operation is subject to the following two conditions: (1) This device may not cause harmful interference, and (2) this device must accept any interference received, including interference that may cause undesired operation.

Revision history

Date	Description	Revision
June 2021	Minor updates.	A.4
April 2021	Added reader power select table in 2.6 Reader wiring .	A.3
February 2021	Correction to LP4502 connections.	A.2
January 2021	Add J19: Battery backup call out to the hardware diagram.	A.1
October 2020	Initial release.	A.0



Powering Trusted Identities

Americas & Corporate
611 Center Ridge Drive
Austin, TX 78758
USA

Support: +1 866-607-7339

Asia Pacific
19/F 625 King's Road
North Point
Island East
Hong Kong

Support: +852-3160-9833

Europe, Middle East & Africa
3 Cae Gwyrdd
Green Meadow Springs
Cardiff, CF15 7AB
United Kingdom

Support: +44 (0) 1440 711 822

Brazil
Condomínio Business Center
Av. Ermano Marchetti, 1435
Galpão A2 - CEP 05038-001
Lapa - São Paulo / SP, Brazil
Phone: +55 11 5514-7100

PLT-05246, A.4