

# **HID® Mercury™ LP2500 Controller**

## Installation and Specifications

PLT-05245, A.2  
August 2022



## Copyright

© 2020 - 2022 HID Global Corporation/ASSA ABLOY AB. All rights reserved.

This document may not be reproduced, disseminated or republished in any form without the prior written permission of HID Global Corporation.

## Trademarks

HID GLOBAL, HID, the HID Brick logo, and HID Mercury are trademarks or registered trademarks of HID Global, ASSA ABLOY AB, or its affiliate(s) in the US and other countries and may not be used without permission. All other trademarks, service marks, and product or service names are trademarks or registered trademarks of their respective owners.

## Contacts

For technical support, please visit: <https://support.hidglobal.com>.

## What's new

Date	Description	Revision
August 2022	New branding.	A.2

A complete list of revisions is available in [Revision history](#).

# Section 01

Overview



# Section **02**

LP2500 wiring and setup

## 2.1 LP2500 connections

<b>TB1-1</b>	GND	Power fault input
<b>TB1-2</b>	FLT	
<b>TB1-3</b>	GND	Cabinet tamper input
<b>TB1-4</b>	TMP	
<b>TB1-5</b>	GND	Power input
<b>TB1-6</b>	VIN: 12 to 24 V DC	
<b>TB2</b>	N/A	Not used
<b>TB3-1</b>	GND	SIO Port 1 (2-wire RS-485)
<b>TB3-2</b>	TR- (B) <sup>1</sup>	
<b>TB3-3</b>	TR+ (A) <sup>1</sup>	
<b>TB4-1</b>	GND	SIO Port 2 (2-wire RS-485)
<b>TB4-2</b>	TR- (B) <sup>1</sup>	
<b>TB4-3</b>	TR+ (A) <sup>1</sup>	

1. Terms (A) and (B) are from the RS-485 standard.

## 2.2 Jumpers and jacks

The LP2500 controller hardware interface is configured using jumpers to setup the port interface and end of line termination.

Jumpers	Set at	Description
<b>J1</b>	N/A	10-BaseT/100Base-TX Ethernet port
<b>J2</b>	N/A	Factory use only
<b>J3</b>	N/A	Factory use only
<b>J4</b>	OFF	Port 1 RS-485 EOL Terminator is OFF
	ON	Port 1 RS-485 EOL Terminator is ON
<b>J5</b>	OFF	Port 2 RS-485 EOL Terminator is OFF
	ON	Port 2 RS-485 EOL Terminator is ON
<b>J6</b>	N/A	microSD card
<b>J7</b>	N/A	USB port (2.0)
<b>J8-1</b>	N/A	Remote Status LED #1. <sup>1</sup>
<b>J8-2</b>	N/A	Remote Status LED #2. <sup>1</sup>
<b>J8-3</b>	N/A	Remote Status LED #3. <sup>1</sup>
<b>J8-4</b>	N/A	Remote Status LED #4. <sup>1</sup>
<b>J19</b>	OFF	Backup battery is OFF
	ON	Backup battery is ON. See <a href="#">2.8 Memory and real time clock backup battery</a>

1. Observe polarity connection to LED. External current limiting is not required.

## 2.3 DIP switches

The four switches on S1 DIP switch are used to configure the operating mode of the LP2500 controller. DIP switches are read on power-up except where noted. Pressing reset switch S2 causes the LP2500 to reboot.

1	2	3	4	Definitions
OFF	OFF	OFF	OFF	Normal operating mode.
ON	X	OFF	OFF	After initialization, enable default User Name (admin) and Password (password). The switch is read on the fly, a reboot is not required. See <a href="#">2.10 IT security</a> for additional information.
OFF	ON	OFF	OFF	Use factory default communication parameters.
ON	ON	OFF	OFF	Use OEM default communication parameters. Contact system manufacture for details. See <a href="#">2.5 Bulk erase configuration memory</a> .
ON	ON	OFF	OFF	Bulk erase prompt mode at power up. See <a href="#">2.5 Bulk erase configuration memory</a> .
X	X	X	ON	Makes the LP2500 report and function like an EP2500. To be used in situations where the host software has not been updated to support the LP series product line.

**Note:** All other switch settings are unassigned and reserved for future use. X = don't care.



**Caution:** In the factory or OEM default modes, downloaded configuration/database is not saved to flash memory.

## 2.4 Factory default communication parameters

### Interface 1 (NIC1)

<b>Network: static IP address</b>	192.168.0.251
<b>Subnet mask</b>	255.255.0.0
<b>Default gateway</b>	192.168.0.1
<b>DNS server</b>	192.168.0.1
<b>Primary host port</b>	IP server, Data security: TLS if Available, port 3001, communication address: 0
<b>Alternate host port</b>	Disabled



## 2.5 Bulk erase configuration memory

The bulk erase function can be used for the following:

- Erase all configuration and cardholder database (sanitize board, less third party applications).
- Update OEM default parameters after OEM code has been changed.
- Recover from database corruption causing the LP2500 board to continuously reboot.

**Note:** If clearing the memory does not correct the initialization problem, contact Tech Support ([TechSupport@Mercury-Security.com](mailto:TechSupport@Mercury-Security.com)).

### 2.5.1 Bulk erase steps

1. Set S1 DIP switches 1 and 2 to **ON**, and 3 and 4 to **OFF**.
2. Apply power to the LP2500 board. LED 1 is on for about 15 seconds while LP2500 boots up.
3. Change DIP switches 1 or 2 to **OFF** Within 10 seconds after LEDs 1 and 2, and LEDs 3 and 4 start flashing alternately at a rate of 0.5 seconds. If these switches are not changed, the LP2500 board will power up using the OEM default communication parameters.
4. LED 2 will flash indicating that the configuration memory is being erased. Full memory erase takes up to 60 seconds.
5. When complete, only LEDs 1 and 4 will flash for about three seconds.
6. The LP2500 board will complete its initialization within two seconds after LEDs 1 and 4 stop flashing.



**Caution:** Do not remove power during the bulk erase process.

## 2.6 Input power, cabinet tamper, and UPS fault input wiring

The LP2500 requires 12 to 24 V DC power. Locate power source as close to the unit as possible.

**Connect power with minimum of 18 AWG wire. Connect the GND signal to earth ground in ONE LOCATION within the system! Multiple earth ground connections may cause ground loop problems and is not advised.**

**Observe POLARITY on 12 to 24 V DC input!**

There are two dedicated inputs for cabinet tamper and UPS fault monitoring. Normal (safe) condition is a closed contact. If these inputs are not used, install a jumper wire.

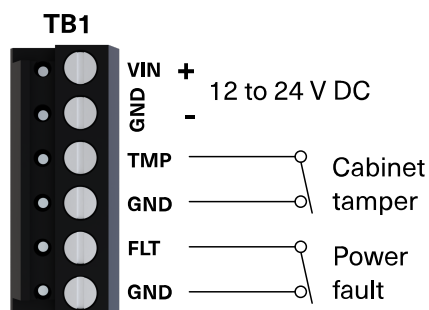

## 2.7 Communication wiring

The LP2500 controller communicates with the host via: on-board Ethernet 10-BaseT/100Base-TX port and/or the USB port (2.0) with an optional Micro USB to Ethernet adapter.

Ports 1 and 2 use a 2-wire RS-485 interface. The interface allows multi-drop communication on a single bus of up to 4,000 feet (1,219 m). Use 1-twisted pair, shielded, 120Ω impedance, 24 AWG. 4,000 feet. (1,219 m) maximum cable length.

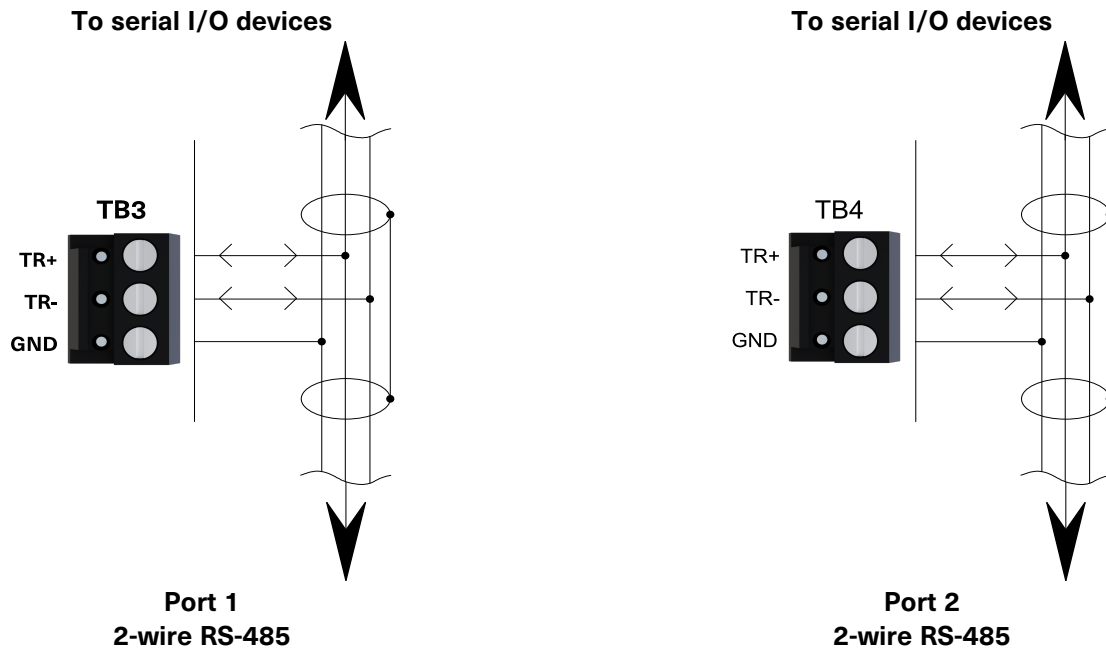

**Caution:** Install the termination jumper **ONLY** on the panel at each end of the RS-485 bus. Failure to do so will compromise the proper operation of the communication channel.

## 2.8 Memory and real time clock backup battery

The static RAM and the real time clock are backed up by a lithium battery when input power is removed. This battery should be replaced annually. If data in the static RAM is determined to be corrupt after power up, all data, including flash memory, is considered invalid and is erased. All configuration data must be re-downloaded.

During installation and while the unit is not powered, change the jumper position (J19) from **OFF** to **ON** to enable the battery backup.

**Battery type:** BR2330 or CR2330.

## 2.9 Status LEDs

### 2.9.1 Power-up

All LEDs are OFF.

### 2.9.2 Initialization

After power is applied or reset switch pushed, LED 1 is ON for about 15 seconds, then LEDs 2 through 6 are flashed once at the beginning of initialization. LEDs 3 and 4 are turned ON for approximately 1 second after the hardware initialization has completed, then the application code is initialized. The amount of time the application takes to initialize depends on the size of the database, about 1 second without a card database. Each 10,000 cards will add about 2 seconds to the application initialization. When LEDs 1 through 4 flash at the same time, data is being read from or written to flash memory, do not cycle power when in this state. If the sequence stops or repeats, perform the bulk erase procedure, see [2.5 Bulk erase configuration memory](#).

### 2.9.3 Running

LED	Description
1	Off-line / On-line and battery status
	Off-line = 20% ON, On-line = 80% ON
	Double flash if battery is low
2	Host communication activity (Ethernet)
3	Port 1 communication activity
4	Port 2 communication activity
5	Unassigned
6	Unassigned
D28	Ethernet activity (Ethernet Port 0)
YEL	On-board Ethernet speed: OFF = 10Mb/S, ON = 100Mb/S (Yellow LED)
GRN	OFF = No link, ON = Good link (Green LED), Flashing = Ethernet activity

## 2.10 IT security

Ensure that the LP2500 is installed securely. Create user accounts to the web configuration page using secure passwords.

Ensure all DIP switches are to be in the **OFF** position for the normal operating mode.

The LP2500 is shipped from the factory with a default login account, which is enabled when DIP 1 is moved from **OFF** to **ON** (See [2.3 DIP switches](#)). The default login user name (admin) and password (password) will be available for five minutes once the DIP switch is toggled. It is therefore important that at least one user account is defined, and the DIP switches are set to **OFF** before the LP2500 is commissioned.

Configuring the LP2500 with an IP address that is accessible from the public is **not** recommended.

The following options are available for enhanced network security:

- Disable SNMP.
- Zeroconf discovery.
- The web configuration module.
- Enable data encryption over the host communication port.

# Section **03**

Specifications

The interface is for use in low voltage, Class 2 Circuits only.

The installation of this device must comply with all local fire and electrical codes.

<b>Primary power</b>	12 to 24 V DC ± 10%, 250 mA maximum (USB port current not included)
<b>Micro USB port</b>	5 V DC, 500 mA maximum (add 270 mA to primary power current)
<b>Memory and clock backup</b>	3 Volt Lithium, type BR2330 or CR2330
<b>microSD card</b>	Format: microSD or microSDHC; 2GB to 8GB
<b>Host communication</b>	Ethernet: 10-BaseT/100Base-TX and Micro USB port (2.0) with optional adapter: pluggable model USB2-OTGE100
<b>Serial I/O device</b>	Two each: 2-wire RS-485, 2,400 to 115,200 bps, asynchronous, half-duplex, 1 start bit, 8 data bits, and 1 stop bit
<b>Inputs</b>	Two unsupervised dedicated for cabinet tamper and UPS fault monitoring
<b>CABLE REQUIREMENTS</b>	
<b>Power</b>	1 twisted pair, 18 AWG
<b>Ethernet</b>	Cat 5, minimum
<b>RS-485</b>	1 twisted pair, shield, 120Ω impedance, 24 AWG. 4,000 feet. (1,219 m) maximum cable length
<b>ENVIRONMENTAL</b>	
<b>Storage temperature</b>	-55 to +85°C
<b>Operating temperature</b>	0 to +70°C
<b>Humidity</b>	5 to 95% RHNC
<b>MECHANICAL</b>	
<b>Dimensions</b>	5 inches (127 mm) W x 6 inches (152.4 mm) L x 1 inches (25 mm) H
<b>Weight</b>	4.1 oz. (115 gm) nominal

#### UL294, 6<sup>th</sup> edition Performance Levels

Feature	Level
<b>Standby Power</b>	I
<b>Endurance</b>	IV
<b>Line Security</b>	I
<b>Destructive Attack</b>	I

These specifications are subject to change without notice.

### 3.1 Warranty

Mercury Security warrants the product is free from defects in material and workmanship under normal use and service with proper maintenance for one year from the date of factory shipment. Mercury Security assumes no responsibility for products damaged by improper handling or installation. This warranty is limited to the repair or replacement of the defective unit.

There are no expressed warranties other than set forth herein. Mercury Security does not make, nor intends, nor does it authorize any agent or representative to make any other warranties, or implied warranties, and expressly excludes and disclaims all implied warranties of merchantability or fitness for a particular purpose.

Returns must be accompanied by a Return Material Authorization (RMA) number obtained from customer service, and prepaid postage and insurance.

### 3.2 Liability

The Interface should only be used to control exits from areas where an alternative method for exit is available. This product is not intended for, nor is rated for operation in life-critical control applications. Mercury Security is not liable under any circumstances for loss or damage caused by or partially caused by the misapplication or malfunction of the product. Mercury Security's liability does not extend beyond the purchase price of the product.

### 3.3 Regulatory

This device complies with part 15 of the FCC Rules. Operation is subject to the following two conditions: (1) This device may not cause harmful interference, and (2) this device must accept any interference received, including interference that may cause undesired operation.

## Revision history

Date	Description	Revision
August 2022	New branding.	A.2
January 2021	Add J19: Battery backup call out to the hardware diagram.	A.1
October 2020	Initial release.	A.0





hidglobal.com

For technical support, please visit: <https://support.hidglobal.com>

© 2022 HID Global Corporation/ASSA ABLOY AB.

All rights reserved.

PLT-05245, Rev. A.2

Part of ASSA ABLOY